



CDR 100V

Technical data

Sensing element	Non-Dispersive Infrared Detector (NDIR)
Power supply	24 Vac/dc
Consumption	3.5 W max. ; 2.8W avg.
Accuracy	+/-40 ppm +3% of reading @ 25°C
Measurement range	0-2.000 ppm
Stability	< 2% of FS over life of sensor (15 years typical)
Non-linearity	< 1% of FS
Response time	< 2 minutes for 90% step change
Signal update	Every 2 seconds
Warm up time	< 2 minutes (operational) 10 minutes (maximum accuracy)
Output	0-10 Vdc, 2-10 Vdc, 0-5 Vdc or 1-5 Vdc selectable via jumper for CDR 100V 4-20 mA (3-wire) for CDR 100A
Flow rates	Diffusion version 80-120 cc/min.
Operating conditions	0 to +50°C 0 to 95% RH, non condensing
Storage conditions	-40 to +70°C
NDIR life	15 years
Weight	150 g
Dimensions	102 x 90 x 40 mm
Applicable Standards:	EN 55014:2000+A1: 2001+A2: 2002, EN 61000-4-2: 1995+A1: 1998+A2: 2001, EN 61000-4-3: 2002+A1: 2002
Applicable EC directives:	89/336/EEC

Features

- **Outputs**
 - 0-10 Vdc, 2-10 Vdc, 0-5 Vdc or 1-5 Vdc selectable via jumper for CDR 100V
 - 4-20 mA (3-wire) for CDR 100A
- **Power supply** 24 Vac/dc
- **Measures** 0-2.000 ppm
- **Accuracy** +/-40 ppm +3% of reading @ 25°C
- **Self-Calibration** (No re-calibration required)
- **Fifteen years** life time on CO₂ sensor

Description

CDR 100 is used to control CO₂ generator, ventilation or other cool/heat equipments. CDR 100 can also be connected with DDC/PLC controller or other automation system.

Ventilation control by CO₂ is a viable and energy efficient way of controlling ventilation to target cfm/person levels based on actual occupancy. It's reasonable than traditional approach of providing fixed ventilation based on maximum occupancy.

Monitor and control zone ventilation efficiency and take advantage It reduces ventilation and energy costs in applications with variable occupancy. of using preconditioned transfer air from under occupied spaces for ventilation

Applications

- Office premises
- Airports
- Hotels
- Conference rooms
- Restaurants
- Apartments
- Hospitals
- Schools
- Meeting rooms

Ordering

Type no.	Description
----------	-------------

Carbon Dioxide (CO₂) transmitter for room

CDR 100V	0-10 Vdc, 2-10 Vdc, 0-5 Vdc or 1-5 Vdc output selectable via jumper
CDR 100A	4-20 mA output (3-wire)

Mounting and Wire Connection

Notice the supply power voltage of the transmitter: 24Vac/dc.
Do not install the transmitter on voltages higher than marked on the transmitter.

Remove the cover.
Please note, use your nails or other unsharp tools to depress the clips.

Mount the transmitter on the place where you want to detect CO₂ level. Do not mount it near diffuser or any steam source, in direct sunlight.

Mount the main part first, there are two dimensions available.
Place the transmitter against the wall at desired location; make sure wires can be passed through the notch on the back board.

Connect wires to terminal strips,
Make sure wiring connection correct and secure.

Remove the cover

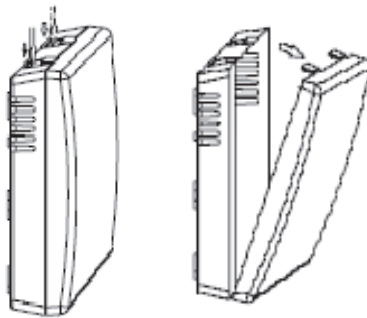

Dimensions in mm

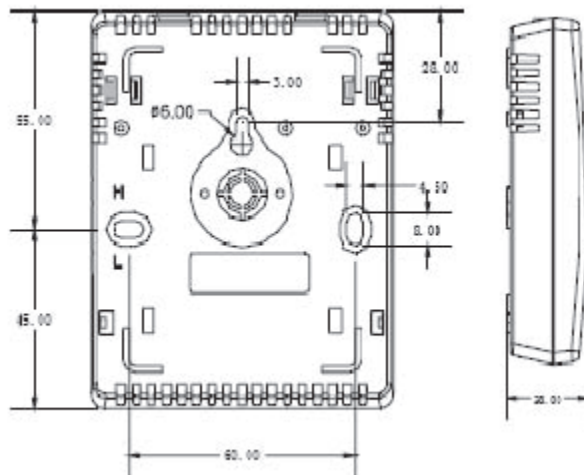

Wiring

CDR 100V with selectable output via jumper
1-5Vdc, 2-10 Vdc, 0-5 Vdc and 0-10 Vdc output

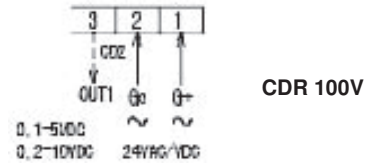

Selection of voltage output via jumpers J1 and J2

J2	J1	output
connection	connection	1-5VDC
disconnection	connection	2-10VDC
connection	disconnection	0-5VDC
disconnection	disconnection	0-10VDC

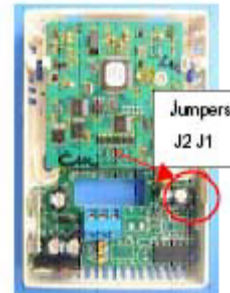

CDR 100A with 4-20 mA output (3-wire)
For 4-20 mA you do not need make any selection via jumpers.

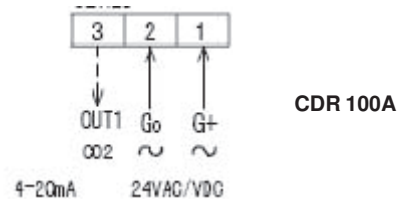

We reserve the right to make changes in our products without any notice which may effect the accuracy of the information contained in this leaflet.